

WTR14 промышленный датчик давления

- Кремниевый пьезорезистивный чип
- Высокая чувствительность
- MEMS Технология
- Низкая цена
- Короткий срок поставки

WTR14 промышленный датчик давления представляет собой

стандартный и экономичный датчик, который предназначен для измерения давления газа, пара, жидкости. Оно подходит почти ко всем применениям в промышленности. Внутри датчика помещен высокочувствительный пьезорезистивный кремниевый сенсор.

Диапазон давления	
Номинальный диапазон	35kPa, 70kPa, 100kPa, 250kPa, 400kPa, 600kPa, 1MPa, 1.6MPa, 2.5MPa, 4MPa, 6MPa, 10MPa, 16MPa, 25MPa (Бар и psi единицы возможны)
Виды давления	Избыточное Абсолютное Мановакуумметрическое
Перегрузка	300%F.S.(≤70kPa) 200%F.S.(<25MPa)
Выходной сигнал	
Выход	4 to 20mA (Hart протокол дополнительно)
Характеристики	
Точность (в том числе линейность, гистерезис, повторяемость)	±0.5%F.S.(Типичный)
Напряжение питания	24VDC
Диапазон термокомпенсации	-10--70°C(типичный)
Диапазон температуры рабочих сред	-30-100°C
Диапазон температуры окружающей среды	-40-85°C
Диапазон температуры хранения	-40-125°C
Коэффициент «нуля»	±1.5%F.S.max.(-20-85°C)
Коэффициент «диапазона»	±1.5%F.S.max.(-20-85°C)
Материал штуцера	Stainless steel 316L, Viton



Штуцер для подключения давления	Смотрите на следующую страницу "Способ заказа"
Степень защиты корпуса	IP65
Масса	Примерно(900г)

Чертеж

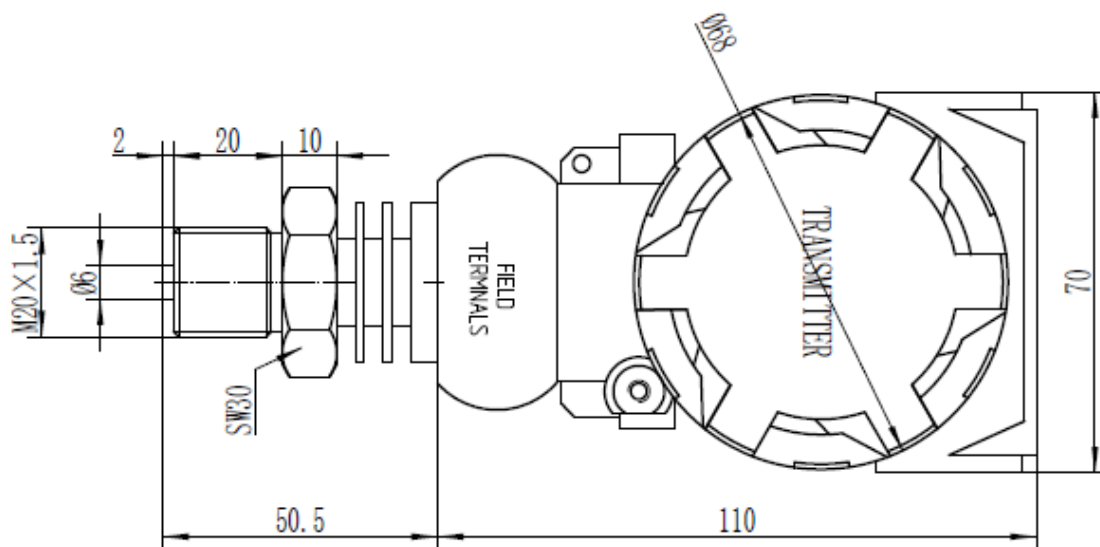

Штуцер для подключения давления

Резьба	M20*1.5	M20*1.5	G1/2
Размер в мм Hex 27mm			
Код	A1(with tube)	A2	A3

Способ заказа

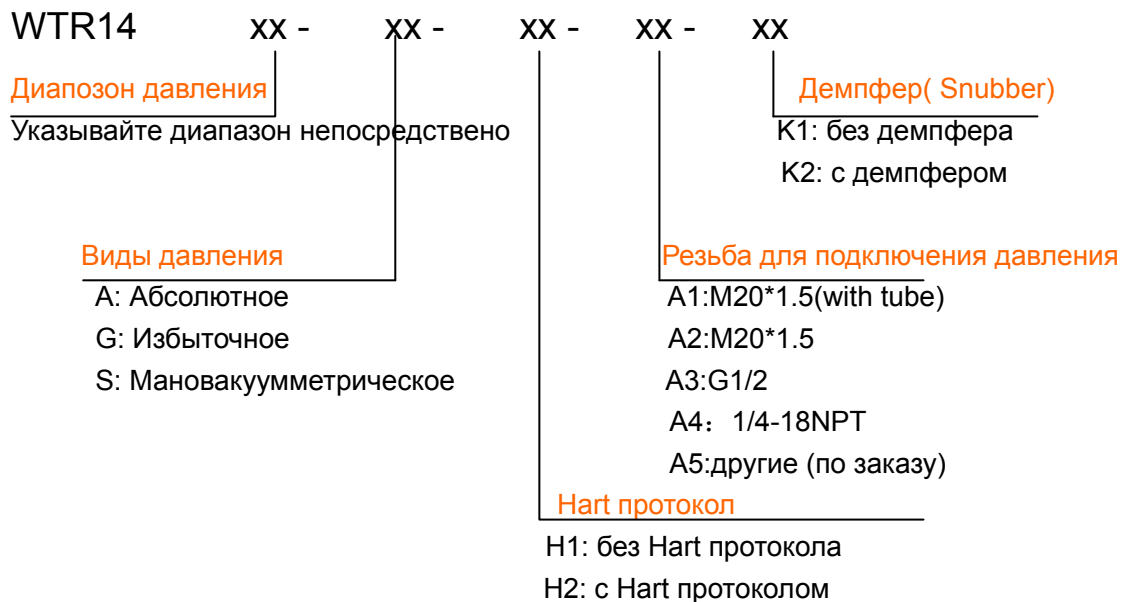

Operation Instruction on Key-press

1. **General Description of LCD Function**
2. **The Function of Key-press**
 - 2.1 Quick search table of key-press function
 - 2.2 Instruction of the key-press mode
 - 2.3 Way on setup data
3. **Operating Instruction of Key-press**
 - 3.1 Function of zeroing main variable
 - 3.2 Function of configuration
 - 3.2.1 General Description of Function
 - 3.2.2 Unit Setup
 - 3.2.3 Span Setup
 - 3.2.4 Damping setup
 - 3.2.5 Output characteristic setup
 - 3.3 Offset shift and span shift (Zero and span setup)
 - 3.4 Displayed variable setup
 - 3.5 Restore factory setup

1. General Description of LCD Display





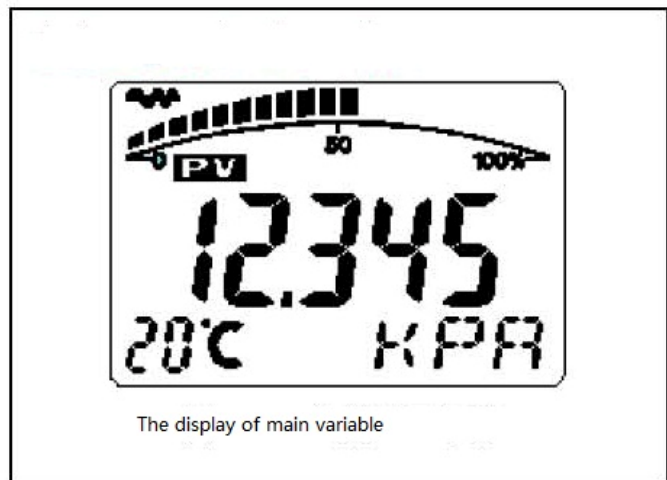
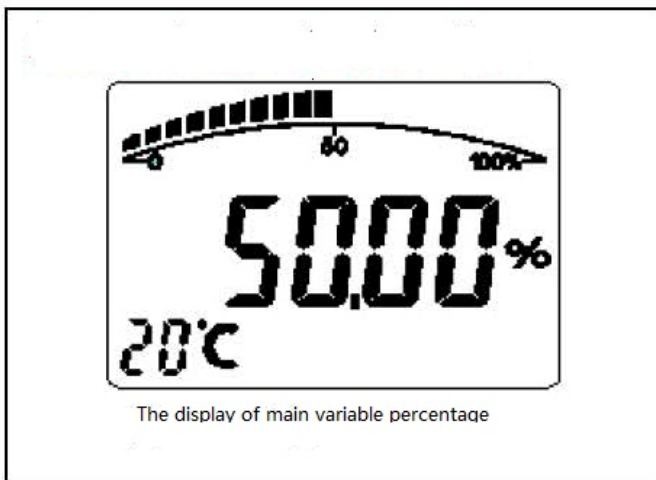
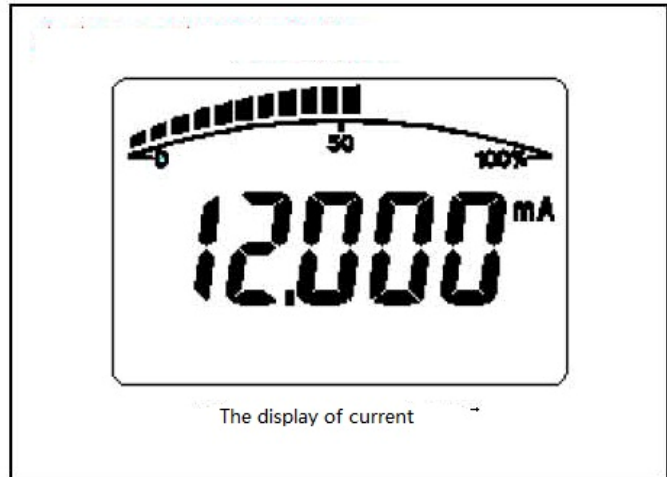
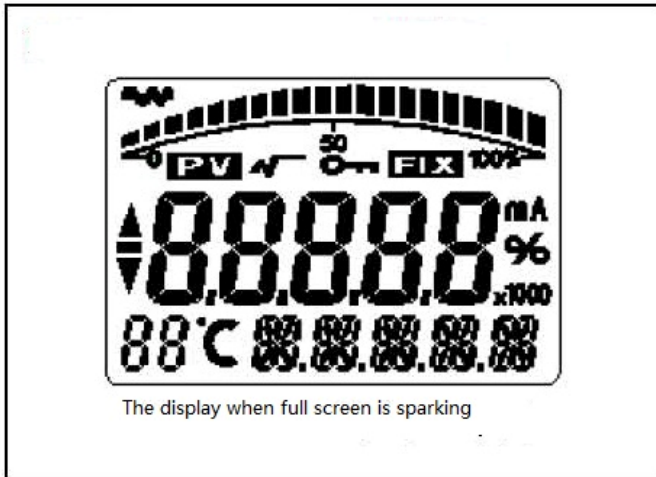

The user can set the variables and decimal digits displayed on LCD by configuration software. Please see the meter configuration ---output characteristics in the part of the configuration software.

LCD supports double variables display. The displayed variables include current, main variable percentage and main variable. Each variable can be set independently to display the position of decimal point: 0, 1,2,3,4.

If the double variables are same, LCD will display one; otherwise LCD will display the variables alternately in 3 seconds interval.



Other display instruction:

- LCD display  sparkingly on the top left corner in communicating situation.
- LCD display  if extraction outputs
- LCD display  if you fix output current
- LCD display  if operate writing-protection
- LCD displays temperature on the low left corner where the character 88 display when normal real-time display; LCD display   when the temperature is below -19°C or over

99°C

2. The Function of Key-press

The functions of key-press include main variable zero setup; zero shift (zero setup), span shift (span setup); unit setup, span setup, damping setup, as well as displayed variables setup.

2.1 Quick search table of key-press function code

The characters 88 on the low left corner of LCD mean the current setup variable type, which is the current setup function performed by key-press. The corresponding relations are as followings:

Display 88 characters on the low left corner	Variables setup
0 or blank	Normal display
1	Input the operating code(you can input the corresponding digit to set up the corresponding function directly)
2	Unit setup
3	Lower range value setup
4	Upper range value setup
5	Damping setup
6	Main variable zero setup
7	Zero shift and span shift(zero and span setup)
8	Output characteristics(set up the linearity output or extraction output)

Remark: Through inputting each corresponding function code, the corresponding function can be entered quickly. For example input 5, you can enter the function of the damping setup directly.

2.2 The instruction on key-press mode

The product supports two kinds of operating mode which are double key-press and three key-press.

Three key-press operating mode: operate more quickly, suitable for LCD with three key-presses. At this time Z key is used to enter the interface of hinting data setup and shift; S key is used to enter the interface of data setup, adding data and saving data; M key is used to save data.

Double key-press operating mode: suitable for the situation that there are only two external key-presses which can not be contacted. At this time Z key is used to enter the interface of hinting data setup and shift; S key is used to enter the interface of data setup, adding data and (storing) save data.

2.3. The method on setup data

When the characters 88 display 1---7, the transmitter is on the mode of locale configuration. At this time can input the secret code, modify the parameter or make transference.

In the process of setup data, S key is used to adjust data and decimal point; Z key is used to transfer; M key is used to (store) save.

The setup processes are as followings:

- a. Press S, enter the interface of data setup, meanwhile the digit of symbol begins



- sparkling, which means the digit of symbol can be modified.
- If press S again, you can switch the positive or negative data(upper arrow means positive)
 - Press Z, the first digit starts sparkling, which means you can modify; At this time press S key for a long time or press time after time, the setup digits circulate between 0—9.
 - Press Z again, you can set the second to fifth digits in turn; the way is as same as the first digit.
 - After setup the fifth digit, press Z, begin to set decimal point. When four decimal points begin sparkling at the same time, it means you can set the points, press S at this time, the positions of decimal point switch circularly.
 - After finishing the setup of the decimal points, press Z , the low left arrow is sparkling, which means you can save the setup.
 - Press S, save the setup; press Z , the digit of symbol begins sparkling, you can reset the data.

Remark: If in three key-press operating mode, in the process of setup the data, press M key at any time, you can save the setup quickly, need not to save the data after the arrow sparkling.

3. Operating Instruction of Key-press

3.1 The function of zeroing the main variable

In the current normal situation, press M+Z at the same time, hold five seconds, you can enter the function of zeroing the main variable directly.

Remark: a. Only the circuit board above software edition 1.4 can support to enter the function quickly through M+Z.

b. You should input the operating mode 2 to enter the setup function or input 6 to enter directly for earlier edition.

After entering the function of zeroing the main variable, 6 is displayed on the low left corner, in the middle display the current value of the main variable, in the lower region display “YES” or “NO”。

- When display “YES”, press M or Z, perform the operation of zeroing the main variable. After that the output pressure is 0.
- When display “NO”, press M or Z, and end the operation of zeroing the main variable.
- Press S, you can switch between “YES” or “NO”.

3.2 The function of configuration

3.2.1 The general description of function

In the current normal display situation, press Z to enter the situation of setup the configuration data.

After entering the situation, LCD display 01 in the low left corner, hint to input the operating code. Input different operating code and enter different interface of setup different function. After finishing the function setup, enter the circular setup automatically.

Display 88 characters in the low left corner	Set the variable
2	Unit setup
3	Lower range value setup



5	Damping setup
6	Main variable zero setup
8	Output characteristics(set the linearity or extraction output)

According to the method on setup data in 2.2, you can finish the input of operating code, lower and upper range value setup and damping setup,

Remarks:

- If in two key setup mode, when the lower arrow is sparkling, press S, can perform the saving function of M.
- If the setup data is over the limit, LCD display "OVER", press S or Z to reset.
- After finishing the setup of configuration data and return to the normal display situation, if press Z again within 10 seconds, restart the process of setup configuration data and skip over the process of inputting the test code.
- After entering the setup of configuration data, if press no key within 2 seconds, it will return to the normal display.
- If in function 1, input the operating code, perform the functions as followings:
 Input xxxx2(the front four digits can be any number), you will enter the unit setup.
 Input xxxx3(the front four digits can be any number), it will enter lower and upper range value setup.
 Input xxxx5(the front four digits can be any number), it will enter damping setup.
 Input xxxx6(the front four digits can be any number), it will enter main variable zero setup.
 Input xxxx6(the front four digits can be any number), it will enter the output characteristic adjustment setup.
 If input the other data, it will return to the normal display. Thus man-made wrong operation can be avoided.

3.2.2 Unit setup

In the process of unit setup, LCD displays sparklingly the chosen unit in the low right corner. The processes of unit setup are as followings:

- 1) Press S, choose the unit of the main variable in turn: (kPa, Torr, atm, MPa, inHO, inHG, ftHO, mmHO, mmHG, psi, bar, mbar, gcm, kgcm, Pa etc.)
- 2) Press Z or M, confirm the current chosen unit of the main variable, enter the function interface of the upper and lower range setup.

Remark:

- The displayed unit "l4H2O" means 4°C inches of water.
- The displayed unit "m4H2O" means 4°C millimeter of water

3.2.3 Span setup

When set span, the lower limit must be input first, and then input the upper limit.

In the process of span setup, the operating code display 03 or 04 on the low left corner. They are corresponding to the lower limit or upper limit respectively. After finishing setup the lower limit, it will enter the setup of upper limit automatically.

The method of inputting the data see "the method on setup the data in 2.2".

3.2.4 Damping setup

Enter the interface of the damping setup directly through input the operating code "5", or

enter the setup of the damping directly after finishing setup the upper limit of span. When the operating code displays “05” on the low left corner, it means to set the value of damping. The input range of the damping value is 0---32seconds.

The methods on inputting the data see “the method on setup the data in 2.2”.

Special remarks: If you input the damping value “05678”, then it will perform the operation of restoring factory setups automatically. (Data backup should be performed before leaving the factory)

3.2.5 Output characteristic setup

In the process of setup the output characteristic, LCD display sparkingly the current chosen output characteristic on the low right corner(linearity output LIN or extraction output SQRT). The setup processes are as followings:

- 1) Press S, choose the output mode of the current in turn: (LIN, SQRT)
- 2) Press Z or M, confirm the chosen output characteristic, end this round setup, return to the function interface of ending the setup(LCD display the function mode 0 on the low left corner). If press no key within 10 seconds, return to the normal display, otherwise continue setup from span unit (do not need to input the operating code again).

Remark: LIN means linearity current output; SQTR means extraction current output.

3.3 Offset shift and span shift (Zero and span setup)

In the current normal display situation, press Z and S at the same time, holds 5 seconds, enter the situation of offset shift and shift. At this time the operating code displays “07” on the low left corner, which means it can perform the operation of zero and span setup.

“Offset shift”, that is zeroing setup operation: the current pressure setup is the lower limit of the span. The output of the transmitter is adjusted to 4mA.

“Span shift”, that is span setup operation: the current pressure setup is the upper limit of the span. The output of the transmitter is adjusted to 20mA.

In the process of setup, if press no key within 2 seconds, then return to the normal display situation.

3.4 Displayed variable setup

LCD can display one of the three variables “current”, “percentage”, “main variable” or display two alternately(the interval is 4seconds). In the current normal display situation, use key S to modify two displayed variables. When you set the two variables to the same parameter, LCD display one fixed variable. When set the two displayed variables to different parameter, LCD display two variables alternately.

The method is as followings:

Press S, the current displayed variable (e.g. current) changes. “current”, “percentage” and “main variable” will be displayed alternately. When the needed variable (e.g. main variable) is displayed on the screen, please loose S then finish the change of the displayed variable from “current” to “main variable”.

e.g. Suppose the current displayed variable is “current”. We need to set: display“main variable”and “percentage” alternately.

Steps:

Modify the first displayed variable: press S, LCD displays “current”, “percentage”, “main



variable" circularly, when display "main variable", loose S, then it is OK. At this time, LCD displays "main variable" and "current" alternately.

Modify the second variable: when LCD displays "current", press S, LCD displays "current", "percentage", "main variable" circularly, when display "percentage", loose S, then it is OK.

Remark: This function only can be supported by the software edition above 2.5; and after adjustment by pressing key, the digits of decimal point of "current" and "main variable" switch to three digits automatically, "percentage" switches to one digit.

3.5 Restore factory setup

If the transmitter has kept a backup of the configuration data etc. before leaving the factory, then you can input the damping "5678" by key-press to restore factory setups on site.

Backup of configuration data: operate the software HART-CONFIG Tool, in the option of additional function under advanced function, click the key of data backup, then you can make a backup of the information of the unit, span, damping etc..

There are several ways to restore the backup data as followings:

- 1) By the software HART-CONFIG Tool, in the interface of output characteristic under meter configuration, input the damping "5678", and click "read-in", then can restore the backup data 【 hint: when read-in the data, it may hint "unsuccessful communication". It is the normal situation, does not influence restoring the backup data. Because 5678 is not the effective value of damping】
- 2) Restore through the hand instrument HART375. Under "setup in details"→ "the signal situation"→ "damping", input the damping "5678" and read-in, which can restore the backup data 【hint: when read-in the data, it may hint "unsuccessful communication", it is the normal situation, do not influence restoring the backup data. Because 5678 is not the effective value of damping.】 .
- 3) Input and store the value of damping "05678" at fifth item by key-press, which can restore the backup data 【this operation does not influence the real damping value】 .