

PCT120 Armored Temperature Sensor

Features

- Easy to install
- High strength, high pressure resistance
- Integrated structure
- Long-term stable work

Applications

- Petroleum machinery
- Chemical machinery
- Temperature measurement of water or oil in electric power, boiler, natural gas, and environmental protection fields, etc.



Product overview

The PCT120 armored temperature sensor measures the temperature of the measured medium by using the feature that the resistance of the platinum resistor changes with temperature and shows a certain functional relationship. It adopts imported high-performance, high-reliability platinum resistance. It is easy to install and has extremely high vibration resistance and shock resistance. It can directly measure the temperature of liquid and gaseous media in the range of $-50^{\circ}\text{C} \sim 250^{\circ}\text{C}$ in various production processes

Notes:

- 1 When measuring temperature, the temperature measuring element should reach thermal equilibrium with the measured object.
- 2 Make sure the insertion length is accurate.
- 3 Please read the Instruction Manual of the product carefully before installation and check the relevant information of the product.
- 4 Strictly follow the wiring method for wiring; otherwise it may cause product damage or other potential faults.
- 5 Misuse of the product may cause danger or personal injury.

Notes:

- 1 Do not misuse documentation.
- 2 The information presented in this product sheet is for reference only. Do not use this document as a product installation guide.
- 3 Complete installation, operation, and maintenance information is provided in the instructions of the product.
- 4 Misuse of the product may cause danger or personal injury.

Specifications

Temperature range	$-50^{\circ}\text{C} \sim 250^{\circ}\text{C}$ (Maximum)
Graduation	Pt100 A; Pt1000 A
Accuracy	$\pm 0.5\% \text{FS}$
Insulation resistance	100M Ω /250VDC
Response time	$\leq 30\text{s}$
Long term stability	$\leq 0.2\% \text{FS}/\text{year}$
Insertion diameter	$\Phi 8\text{mm}$

Storage temperature	-40°C ~ 85°C
Electrical connection	BP3 housing
Protection	IP65
Material	304
Maximum torque	25Nm

Drawing

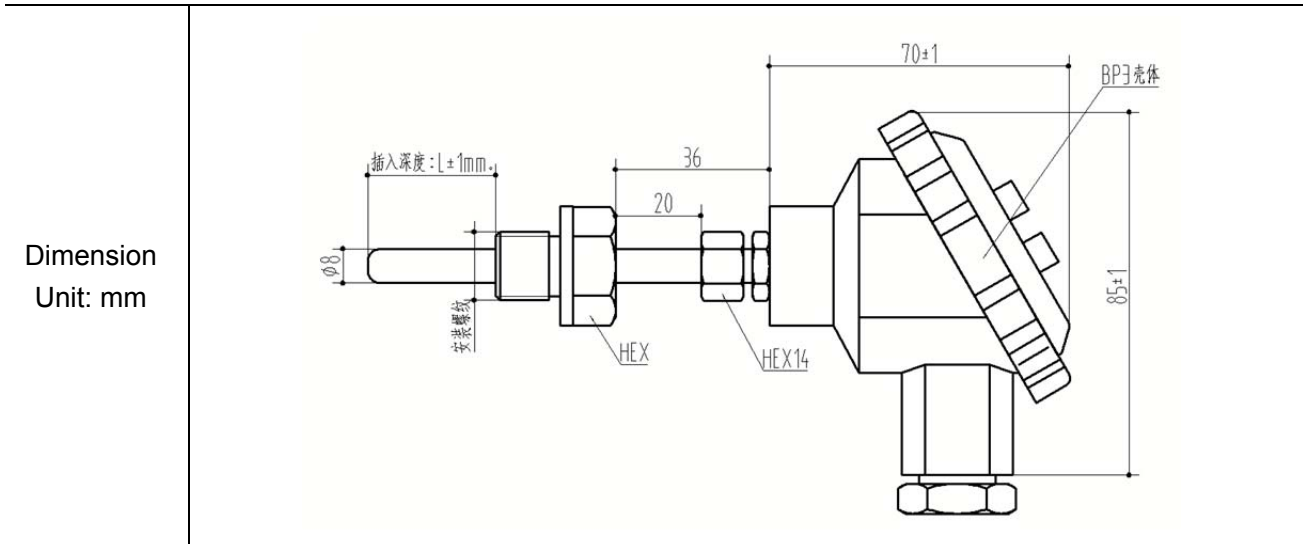

Temperature connection

Thread code	C1: M20×1.5-6g	C2: G1/2
<p>Dimension In mm</p>		
<p>Recommended torque</p>	<p>15~25Nm</p>	<p>15~25Nm</p>
<p>Thread code</p>	<p>C22: M16×1.5-6g</p>	<p>C25: M27×2-6g</p>

<p>Dimension In mm</p>		
<p>Recommended torque</p>	<p>15~25Nm</p>	<p>15~25Nm</p>

Note: Torque depends on various factors such as material of gasket, supporting materials, lubrication of thread and pressure.

How to order

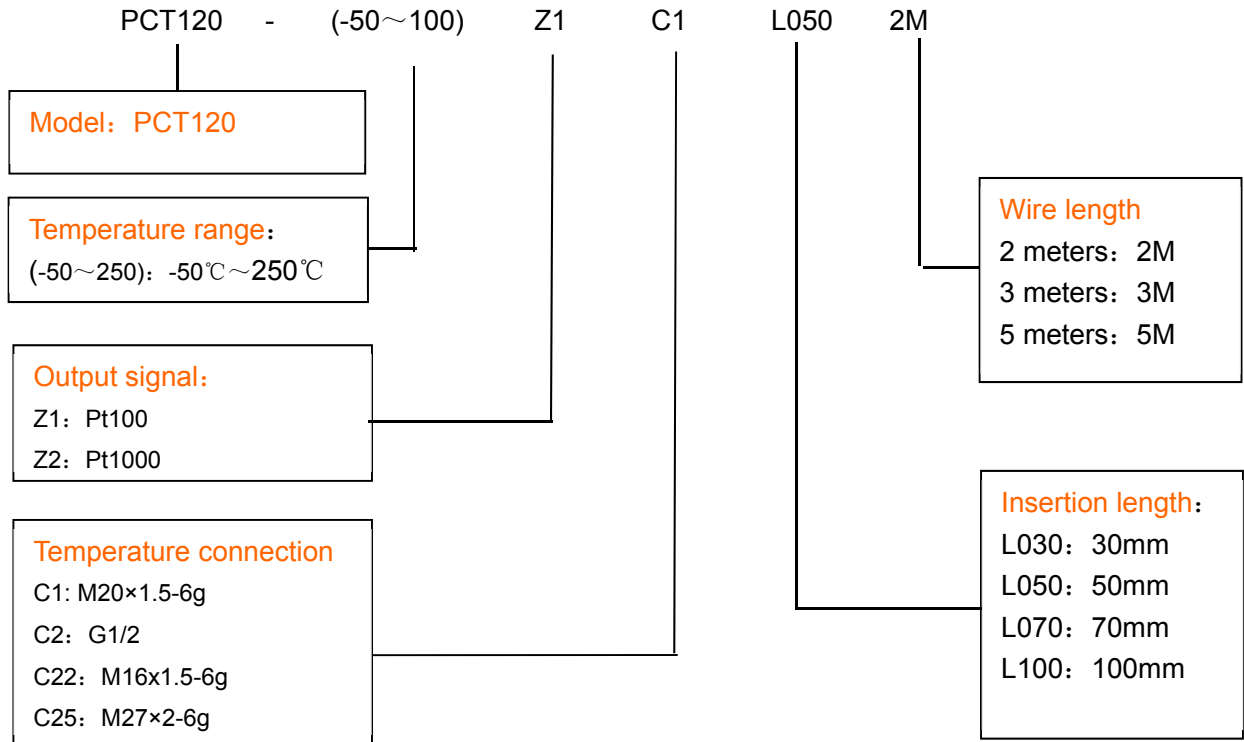

Example: PCT120-(-50~150)Z1C1L050-2M

Refer to product model PCT120, with temperature range -50°C~150°C, sensing element: Pt100 A, pressure port M20×1.5-6g, insertion length 50mm, cable length 2m.

Ordering tips:

- (1) Ensure compatibility between measured media and contacting part of product.
- (2) For special requirements on the product appearance and performance parameters, customization is available.



Wotian reserves the right to make any change in this publication without notice. The information provided is believed to be accurate and reliable as of this product sheet.

Contact us

Nanjing Wotian Technology Co.,Ltd.

Add: 5 Wenyong Road, Binjiang Development Zone, Nanjing, 211161, China

Sales Manager: Wuzhou Lian

MP: 0086-13998828452

Email: lianwuzhou@wtsensorus.com